



BURCKHARDT
OF SWITZERLAND



Precision Perforating Unit
PREMIUM

High-end Perforating Unit PREMIUM

Machine Type	Hot or Cold Pin Perforating Unit
Machine name	Premium
Description	Strong frame Cassette design for high pressure or high precision perforation
Working width	Up to 4000 mm
Perforating roller	Roller \varnothing 180–350 mm Perforating segments according to customer's specification \varnothing over pin tips: 230–400 mm
Counter Roller	Roller \varnothing 200–400 mm Tampico fibre brush Options: (according to application) <ul style="list-style-type: none"> • Rubber • Felt • Female Roller
Heating system	Internal thermo-fluid heating up to 250 °C (measured at perforating ring) Options: <ul style="list-style-type: none"> • Induction heating • Internal electric resistance heating • no heating
Drive system	1 or 2 servo motors, up to 7.5 kW Option: synchronization of the two motors for male/female perforation
Line Speed	Up to 250 m/min (technical speed up to 400 m/min)
Emergency break system	Motor-brake
Penetration adjustment	Electric spindle-lifting device
Electronic control	SPS Control panel with touch screen, digital display suitable for integration into existing line
External dimensions	Total length = working width + 750 mm (motor) + 400 in case of internal oil heating Height: approx. 1300 mm Depth: approx. 860 mm
Additional options	<ul style="list-style-type: none"> • Unit can be installed in horizontal position • Electronic matching control for printed film perforation

For all machine types we are able to adapt to customer's requirements to ensure an optimal end-result.

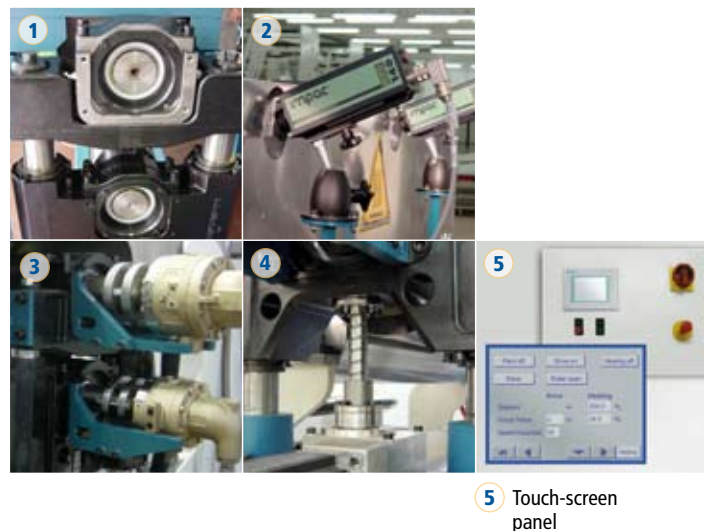
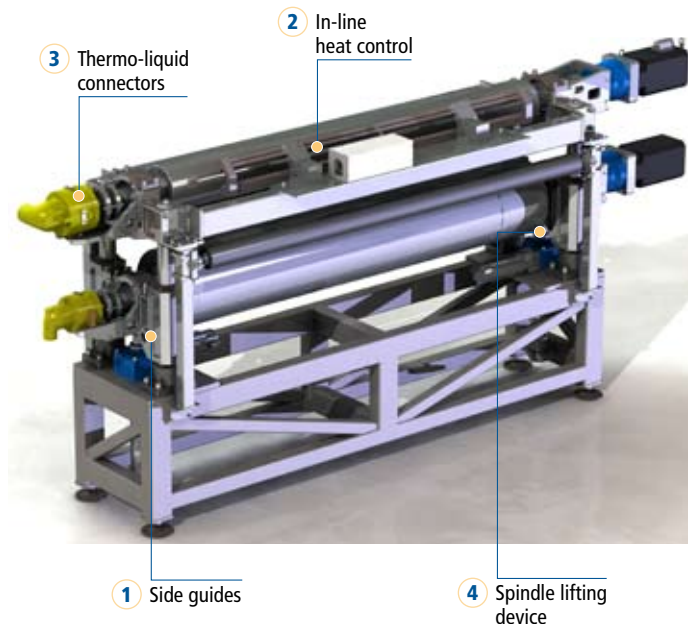

CHRISTOPH BURCKHARDT AG
Pfarrgasse 11, CH-4019 Basel
Switzerland
Tel +41 61 638 18 00
Fax +41 61 638 18 50
info@burckhardt.com
www.burckhardt.com

Please contact us for more detailed information